

Bespoke Granny Annexes

Keep your loved ones close and give them the benefit of independent living

MOBILE
ANNEXE





“ A massive thank-you to Mobile Annexe for helping me realise my dreams.

Anita Clayden
Bishops Stortford ”

By adding a bespoke-built Granny Annexe or Garden Lodge to your property you can enhance the value of your home and enable someone in your family to enjoy an independent life.

We can build your dream one to five bedroom annexe under the scope of a Certificate of Lawful Development, giving you up to 136m² of modern floor space. We obtain the certificate on your behalf from your local council which we have a 100% success rate in obtaining. There is no need to go through a lengthy – and possibly unsuccessful – planning process.

“ I couldn't get planning permission to build an annexe for my son and daughter-in-law. But thanks to MobileAnnexe I now have a stunning 2 bedroom annexe in my garden. Now I see my grand-daughter every day.

Stephen Mason
Saffron Walden

”



Beautiful living spaces created to your specification, offering stylish independent living.



Exceptional finished quality. Let your imagination deliver your dreams.



We offer you the option of a pitched roof or a flat roof.

Pitched roof



Slate



Clay Tiles



Concrete Tiles



Zinc

Flat roof



Torch-on Felt



Asphalt



Fibreglass



EDPM Rubber

External cladding finishes

PVCu

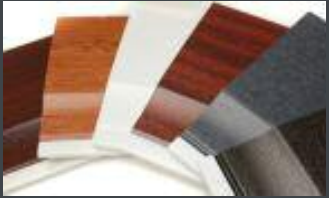

Standard Shiplap



V Groove



Feather-edge Smooth



Double Shiplap Embossed



Feather Edge Embossed



V Groove Embossed

Timber



Shiplap



Halflap



TG&V



Square Edge



Feather Edge



Waney Edge

Fibre cement cladding

C01 White	C02 Beige	C03 Grey Brown	C04 Dark Brown	C05 Grey
C06 Grey Green	C07 Cream White	C08 Sand Yellow	C10 Blue Grey	C14 Atlas Brown
C15 Dark Grey	C18 Slate Grey	C50 Black	C51 Silver Grey	C52 Pearl
C54 Pewter	C55 Taupe	C57 Sage Green	C60 Forest Grey	C61 Burnt Red
C62 Violet Blue				



Smooth or textured click-joint vertical or horizontal



Smooth or textured lap-joint vertical or horizontal

External render finishes

Mineral render

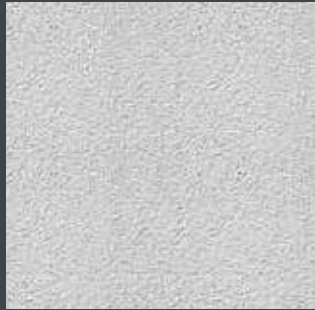

1mm K



1.5 mm K

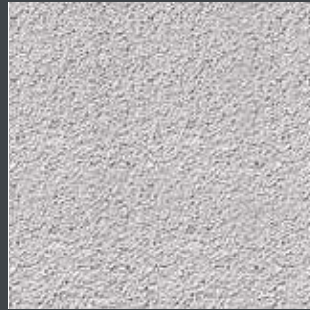

2 mm K

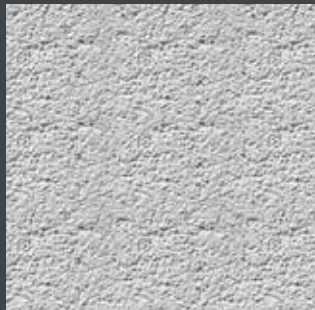

3mm K



1.5 mm R



2 mm R

The Mineral render range can be painted with over 100 standard colours available

Stone render



Bath Stone



Buff Stone



Callow



Cotswold Cream



Country Stone



Perryfield Whitbed

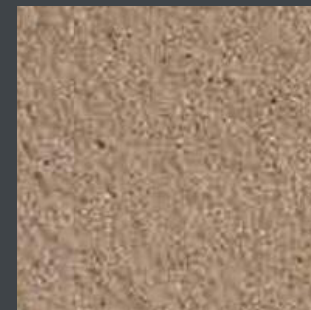

Red Sand Stone

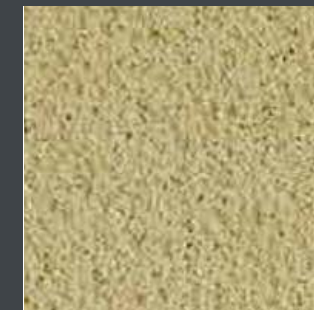

Skipton Stone

External brick finishes

Brick range



Rustic Red Charcoal



Rustic Red Multi



Rustic Orange Multi



Rustic Inferno Multi



Rustic Cottage Multi



Rustic Golden Multi



Rustic Buff Multi



Rustic Cream



Rustic Charcoal



Old Millhouse



Weathered Old Millhouse



Autumn Leaves



London Multi Buff



Colorado



Red Multi



Red Multi Dragwire



Montana Red



Red Dragwire



Red Smooth



Smooth Red Multi

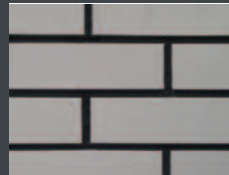

Smooth Grey



Smooth White

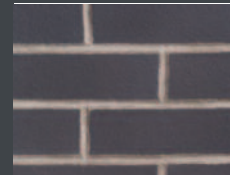

Smooth Anthracite



Newbridge Mix



Islington Yellow Rustica



St Ives Cream Rustica

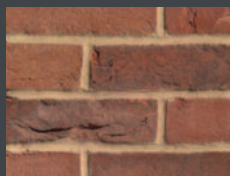

Pastorale



Topaz



Old English



Sanded Red Stock



Whitby Red



Ketley Dudley Blue



London Original Stock

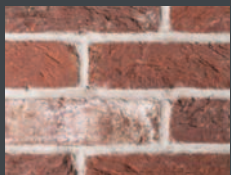

Heritage Red

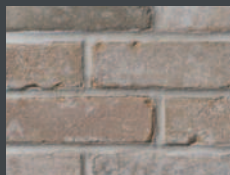

Old Beaufort

Stone range



Square Dressed Penine



Rough Dressed Southwold

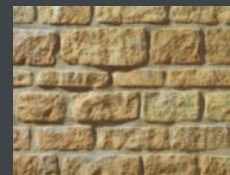

Rough Dressed Cotswold



Traditional Buff Cotswold

Window finishes

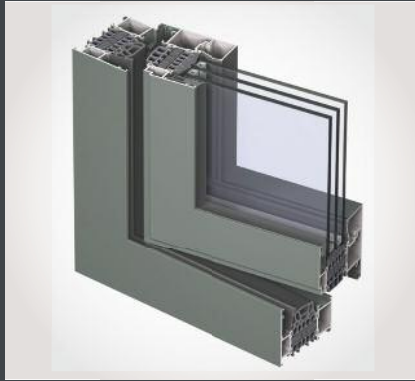

Aluminium

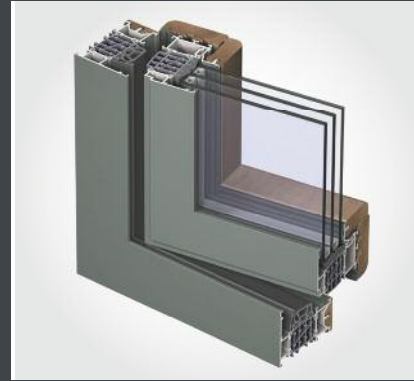

Composite



uPVC



Timber

Window opening styles



Side-Hung Inward



Side-Hung Outward



Top-Hung Outward



Tilt and Turn

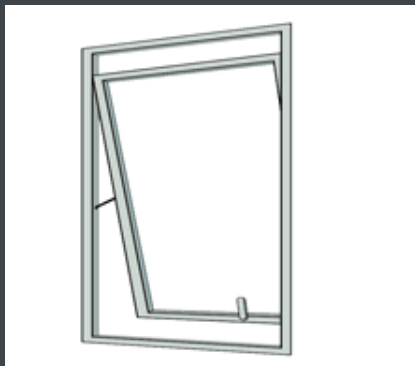

Top-hung Outward Projecting



Pivot Vertical



Pivot Horizontal



Sliding

Door finishes



Aluminium

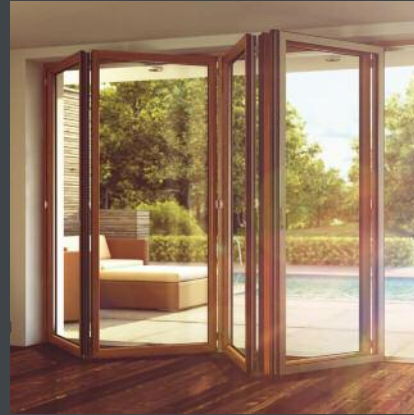

Composite



uPVC



Timber

Door styles



Sliding Doors



Bi-fold



French



French

Prices

All of our annexes are bespoke-built to your specific design. The costs will vary significantly based on a number of factors:

- Extent of the groundworks required
- Door size, style and material: Bi-fold, French, Sliding, uPVC, Timber, Aluminium
- Number of windows and their opening style and material
- External annexe finish: timber, fibre cement cladding, render
- Size and shape of annexe
- Internal fixtures and fittings
- Kitchen
- Flooring

However, a typical 11m x 5m annexe with an angled flat roof as shown below

Costs approximately £89,500*

* The price excludes the flooring and kitchen as prices vary significantly depending on the specification. However, we will offer you our trade discount of up to 70% from certain suppliers and we will fit the kitchen free of charge.



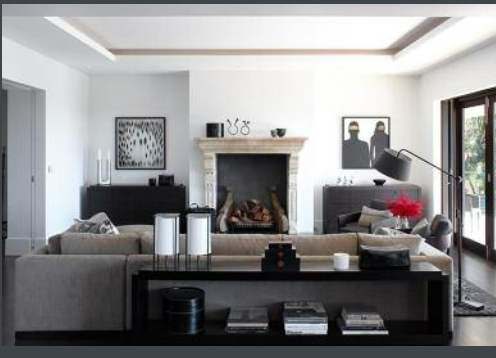

We have an 100% success rate in obtaining a Certificate of Lawfulness with councils.
We can build annexes covering much of Greater London, Essex, Hertfordshire, Mid Bedfordshire and South and East Cambridgeshire, Kent, Suffolk and all areas inside the M25 motorway.



MOBILE ANNEXE

1 Six Cottages, Clapgate,
Albury, Ware, Hertfordshire SG1 12JL

Tel: 07770 365734

Email: enquiries@mobileannexe.com

Complement your home and property with an annexe which allows independent living for your loved ones. Built using advanced modern materials and designs, they look stunning, inside and out. You will surely admire these bespoke Granny Annexes and Garden Lodges from Mobile Annexe.

MOBILE
ANNEXE

