

Acoustic Wall Systems



The UK's leading supplier of acoustic movable walls.

Specialists in supply, installation, service and repairs.

Products | Maintenance | Servicing | Repairs

V1.2



About Acoustic Wall Systems

Having assembled a team of experts in their relevant fields, AWS has rapidly become a recognised name in creating space solutions using movable walls and sliding folding partitions.

AWS promote a technically advanced portfolio of products, both solid and glazed. Available with manual, semi auto and now fully automatic operation, taking each project from design through to installation and ongoing maintenance service.

AWS provide a comprehensive service that has been recognised by leading architects and contractors, from nurseries to universities, from the smallest businesses to international corporations, each project receives the same level of care and attention to detail. Tackling obstacles and obtaining client satisfaction is the philosophy behind AWS.







A100 | Solid Movable Wall System

Dynamically divide spaces up to 10 metres high whilst achieving max sound reduction performance.



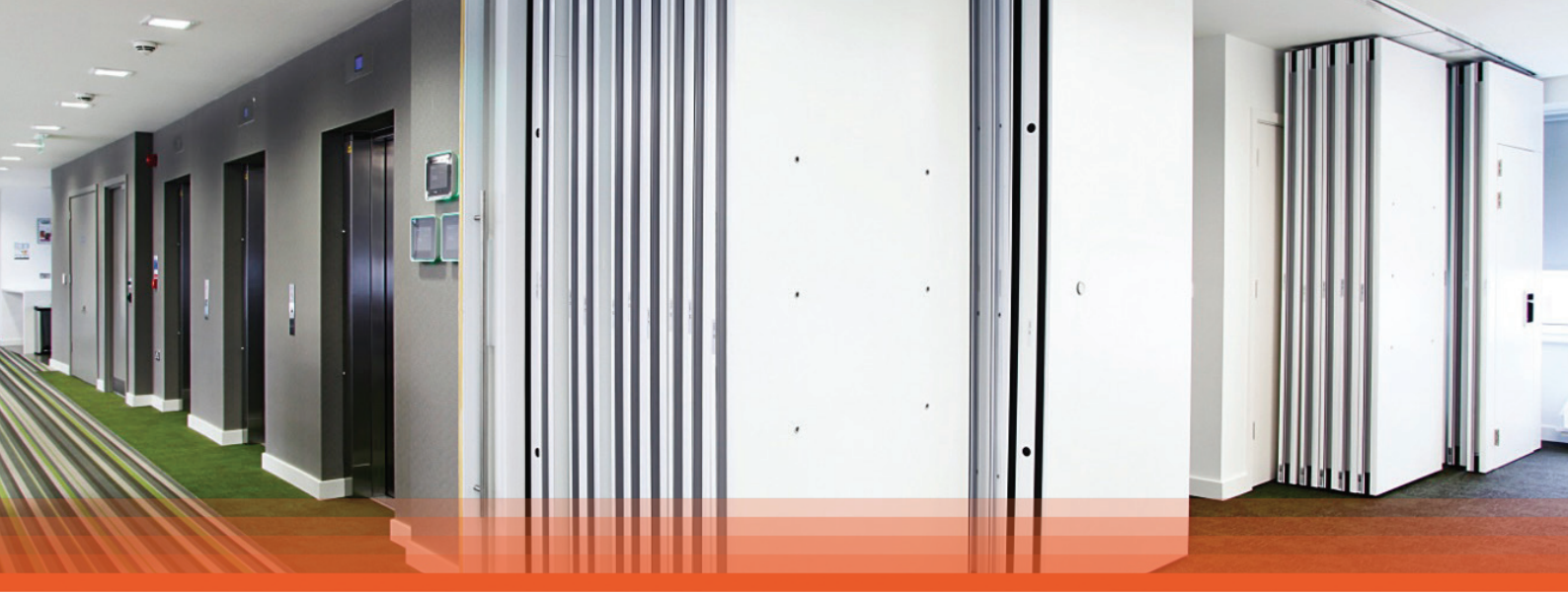

A100 | Solid Movable Wall System

The A100 movable wall system is the ideal solution to dynamically divide spaces up to 10 meters high, assuring perfect sound reduction up to 59dB.

The individual panel system is operated by a scissor jack mechanism within each panel, which is operated manually via a removable handle in the edge profile or with semi-electric operation.

The system is completely top hung and eliminates the requirement for any floor track. Each panel consists of a steel frame covered with a 16mm high density board and infilled with the required acoustic baffle to match the acoustic rating. The A100 system with its wide variety of stacking options, finishes and panels options, is one of the most versatile on the market. Fire rated options are also available.

dB Rating	41	46	51	55	57	59
Panel Thickness	100mm	100mm	100mm	100mm	100mm	100mm
Max Height	10m	10m	10m	10m	10m	10m
Max Length	Unlimited	Unlimited	Unlimited	Unlimited	Unlimited	Unlimited
Weight	38kg m ²	44kg m ²	52kg m ²	55kg m ²	61kg m ²	68kg m ²
Panel Width	600-1250mm	600-1250mm	600-1250mm	600-1250mm	600-1250mm	600-1250mm

Extensive Range of Options

The A100 solid movable wall system offers both functionality and style.

- ✓ We have a huge range of finishes available including various laminates from leading suppliers, real wood veneers, magnetic dry wipe and fabric wallcoverings. Fabric can be supplied in both standard non acoustic and acoustic absorption from many of the leading suppliers including Kvadrat, Camira and Cara.
- ✓ Bespoke glazing options are available from full panel maximum glazing to DDA compliant vision panels.
- ✓ 30 min fire rated option available with surface spread of flame to Class C.
- ✓ Options to include DDA compliant access doors within panels.

Standard Colour Options

The A100 is available in a range of finishes.



Cross Sections

Track and trolley cross sections.

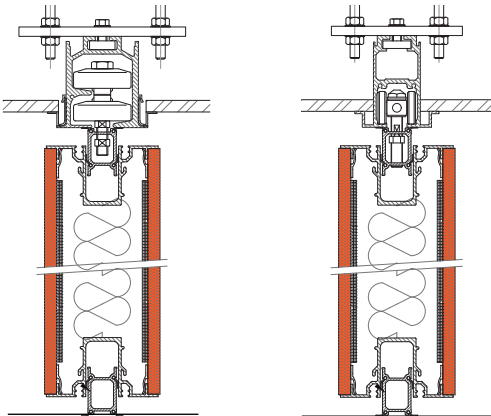

Stacking Arrangement Examples

The A100 is a versatile solution for dividing up large spaces.

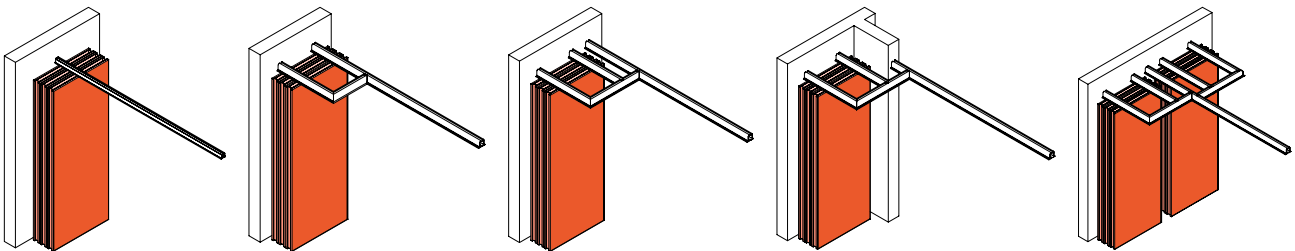

Panel Options

Get the most out of your space with panel and door options.

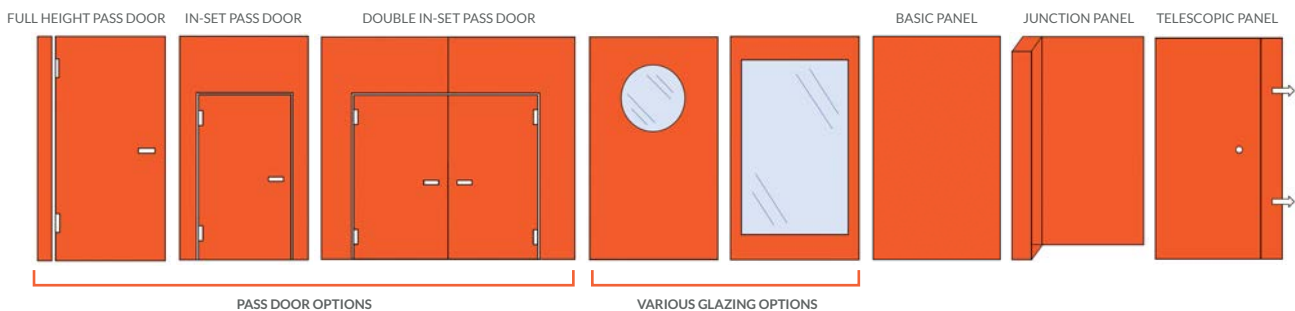



ASF100 | Sliding Folding Wall System

The ideal economical solution for when rapid room layout changes are required within a large space.





ASF100 | Sliding Folding Wall System

The ASF100 wall system is the ideal economical solution for when rapid room layout changes are required.

The panels of the ASF100 are continuously hinged to create a concertina style wall with the leading panel supplied as a pass door as standard.

The ease of operation allows for the lightweight wall to be fitted in all environments including schools, nurseries, leisure centres, nursing homes and offices. With an acoustic performance of up to 49dB and options to have the system as floor supported with an in-set floor track, the ASF100 also comes with various stacking options including bi-parting, single wing, centre folding and end folding.

dB Rating	38	42	46	49
Panel Thickness	80mm	80mm	80mm	80mm
Max Height	4m	4m	4m	4m
Max Width	15m	15m	15m	15m
Weight	20kg m ²	26kg m ²	38kg m ²	42kgm ²
Panel Width	450-950mm	450-950mm	450-950mm	450-950mm

Extensive Range of Options

The ASF100 sliding/folding wall system offers performance and functionality

- ✓ We have a huge range of finishes available including laminates from the UK's leading suppliers like Duhospan and Formica, real wood veneers and magnetic dry wipe boards.
- ✓ Bespoke glazing options available from full panel maximum glazing to DDA compliant vision panels.
- ✓ Both top hung and floor supported options available.
- ✓ Various stacking options available.

Standard Colour Options

The ASF100 is available in a range of finishes.



Cross Sections

Track and trolley cross sections.

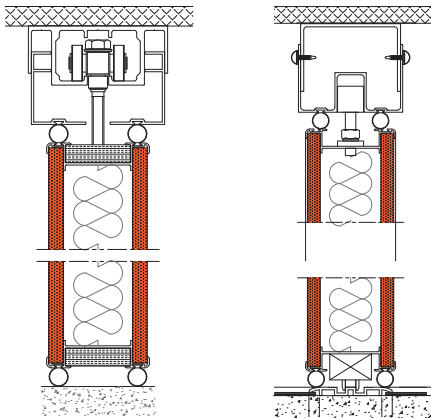

Stacking Arrangement Examples

The ASF100 provides rapid changes to a room's layout.

SINGLE WING - CENTRE FOLDING

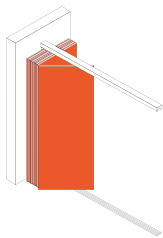

SINGLE WING - END FOLDING

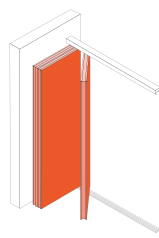

BI-PARTING - END FOLDING

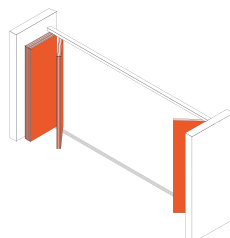

BI-PARTING - CENTRE FOLDING

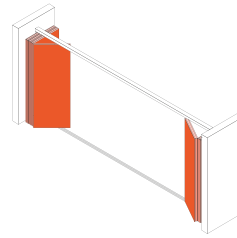

Panel Options

Get the most out of your space with panel and door options.

HALF PANEL

BASIC PANEL

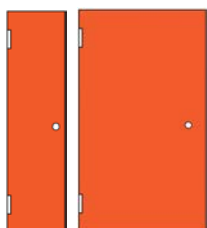

PASS DOOR

DOUBLE PASS DOOR



VARIOUS GLAZING OPTIONS

PASS DOOR OPTIONS

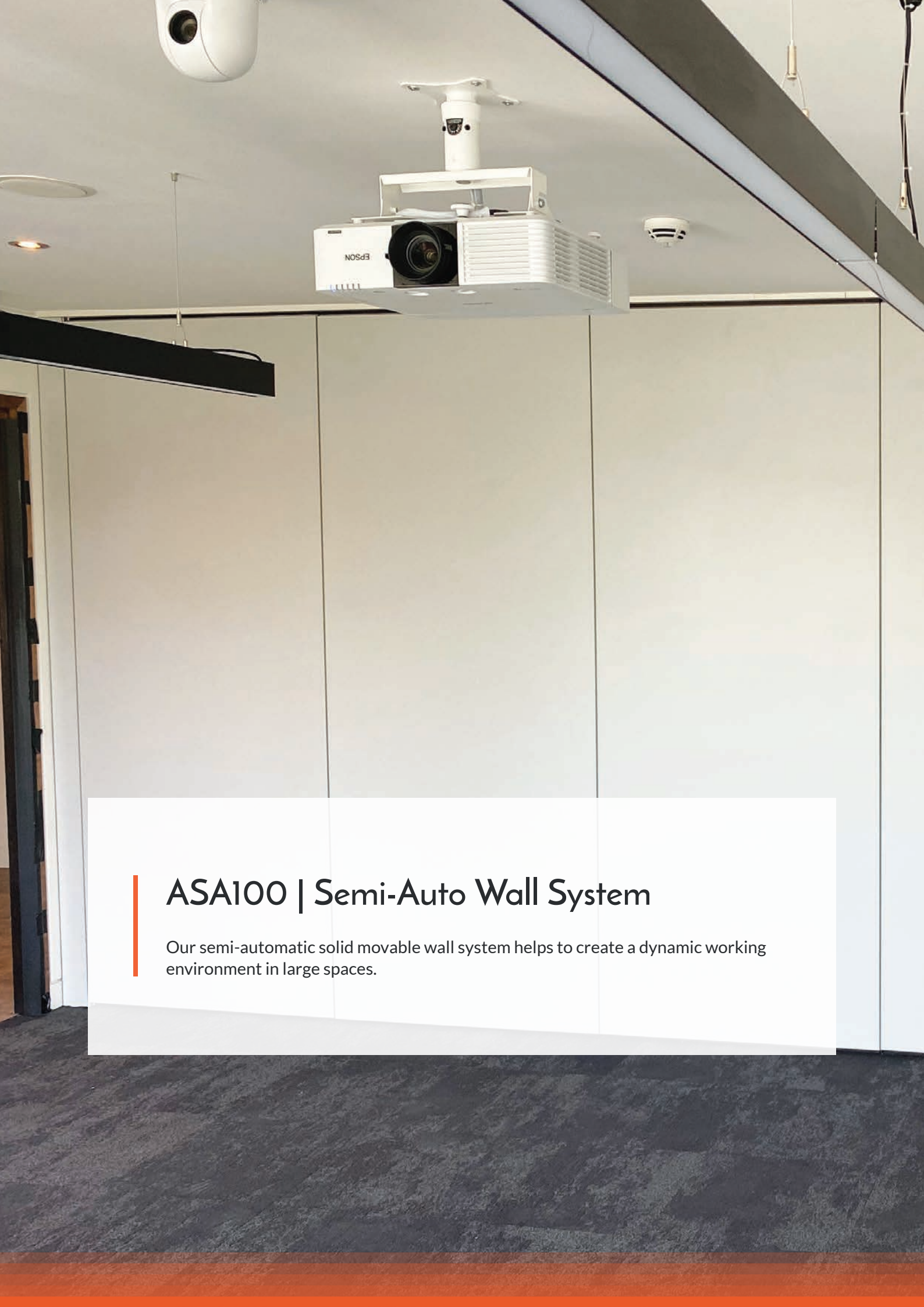

ASA100 | Semi-Auto Wall System

Our semi-automatic solid movable wall system helps to create a dynamic working environment in large spaces.





ASA100 | Semi-auto Wall System

The ASA100 is the semi-automatic version of our A100 solid movable wall system. An ideal solution for creating a dynamic working environment in large spaces.

When each panel is manually set in its position, a series of motorised mechanisms housed within the panel operate the rubber seals and lock the panel in place.

The ASA100 Semi-Auto Wall System Has the same flexibility as the manually operated system and is available with the same stacking arrangements, panel options and finishes.

dB Rating	41	47	50	53	57	60
Panel Thickness	100mm	100mm	100mm	100mm	100mm	100mm
Max Height	10m	10m	10m	10m	10m	10m
Max Length	Unlimited	Unlimited	Unlimited	Unlimited	Unlimited	Unlimited
Weight	38kg m ²	44kg m ²	52kg m ²	55kg m ²	61kg m ²	68kg m ²
Panel Width	700-1250mm	700-1250mm	700-1250mm	700-1250mm	700-1250mm	700-1250mm

Extensive Range of Options

The ASA100 solid movable wall can be customised to suit your environment.

- ✓ Real wood veneers including mahogany, tanganika, douglas, elm, mansonia, ash, pine, oak, teak, chestnut and other finishes are available upon request.
- ✓ Low and high pressure laminates are available.
- ✓ The dry wipe board option can be matched to any RAL Colour with a magnetic version also available.
- ✓ Fabrics available in standard and acoustic from many leading suppliers including Kvadrat, Knoll and Cara .

Standard Colour Options

The ASA100 is available in a range of finishes.



Cross Sections

Track and trolley cross sections.

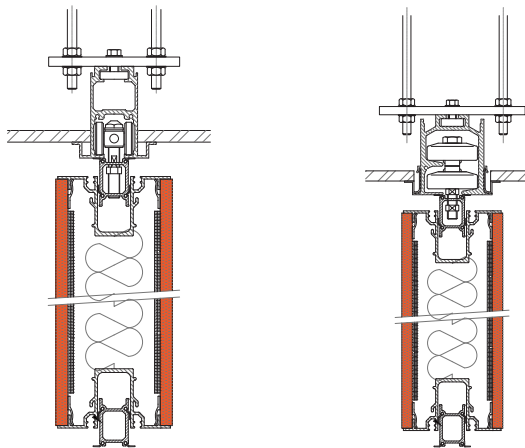

Stacking Arrangement Examples

The ASA100 provides rapid changes to a room's layout.

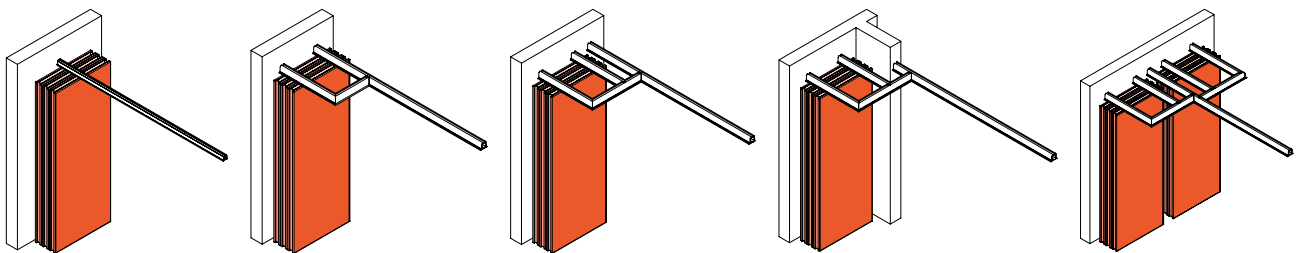

Panel Options

Get the most out of your space with panel and door options.

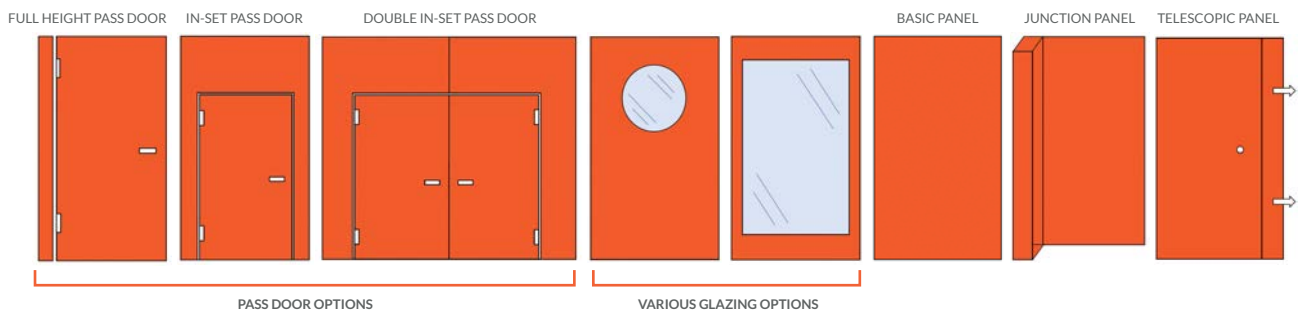



ADG100 | Double Glazed Movable Wall System

The perfect combination of visual transparency with high levels of acoustic performance for your working environment.





ADG100 | Double Glazed Movable Wall System

The double glazed ADG100 is a fully flush glazed movable wall system, which is an ideal solution where light and high acoustic performance are the clients' main objective.

The double glazed ADG100 is a fully flush glazed movable wall system which is an ideal solution where light and high acoustic performance are the clients' main objective.

The system is designed to complement modern fixed partition systems with its aesthetically pleasing design and excellent acoustic performance. The ADG100 can be incorporated with the solid A100 system which allows for flexible space configurations. The system can incorporate internal operational blinds, switchable privacy glass and is available in manual, semi-automatic and now fully automatic operation.

dB Rating	44/49	44/49	44/49
Panel Thickness	100mm	100mm	100mm
Max Height	4m	4m	4m
Max Length	Unlimited	Unlimited	Unlimited
Weight	39/48kg m ²	39/48kg m ²	39/48kg m ²
Panel Width	600mm - 1250mm	600mm - 1250mm	600mm - 1250mm

Extensive Range of Options

The ADG100 double glazed movable wall system features a variety of options.

- ✓ Manifestation films available, offering both style and privacy.
- ✓ Sand blasted designs can be applied to the glass panels.
- ✓ Switchable glass options now available.
- ✓ Remote controlled blinds can be installed, offering privacy.

Manifestation & Colour Options

The ADG100 manifestation film and colour examples.

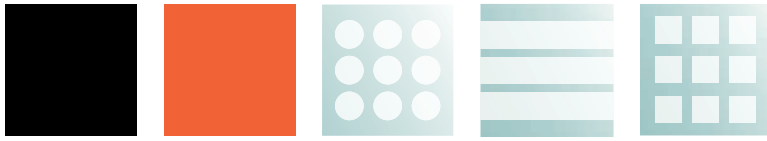

Cross Sections

Track and trolley cross sections.

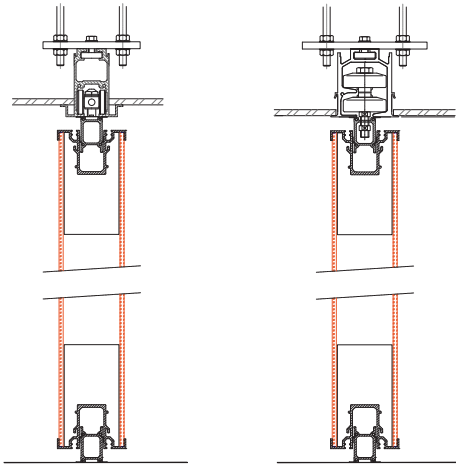

Stacking Arrangement Examples

The ADG100 offers an elegant solution for dividing up larger spaces.

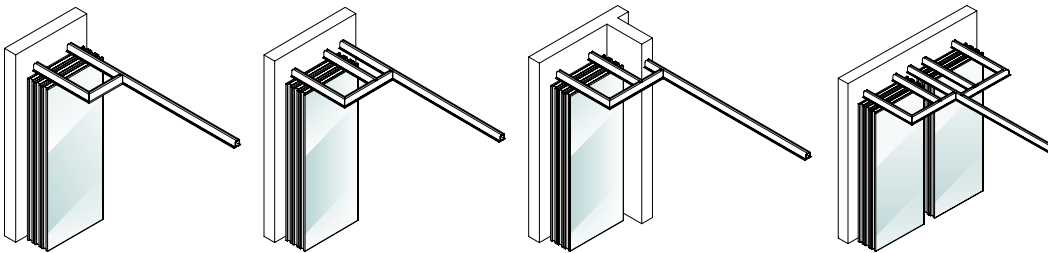

Panel Options

Get the most out of your space with panel and door options.

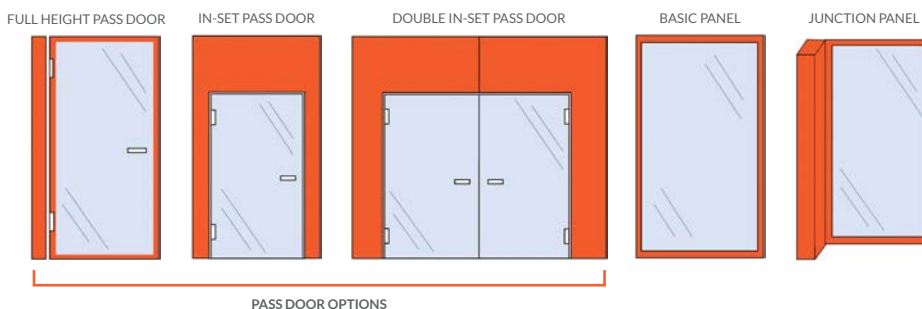



SG35 | Single Glazed Movable Wall System

The SG35 single glazed movable wall system provides uninterrupted visual transparency without the necessity of any acoustic performance.

Cass Business School
CITY UNIVERSITY LONDON





SG35 | Single Glazed Movable Wall System

The SG35 single glazed movable wall system provides uninterrupted visual transparency without the necessity of any acoustic performance.

The SG35 is the ideal solution where space needs to be divided whilst still maintaining a modern open feel to any environment.

The 'glass to glass' system is fitted with a 35mm aluminium frame at the top and bottom to safely and securely hold the 10mm glass in position. Each panel is operated individually and locked into position with a floor bolt for added security. With the option to customise the profiles by powder coating, add any kind of manifestations, sand blasting or back painting, you could create a beautiful bespoke glazed sliding folding partition.

Panel Thickness	Max Height	Max Width	Weight	Panel Width
10mm	3m	Unlimited	35kg/m ²	450mm - 1100mm

Extensive Range of Options

The SG35 is a versatile movable wall system.

- ✓ Available in a wide range of surface finishes.
- ✓ A variety of panel options are available.
- ✓ Sand blasted designs can be applied to the glass panels.
- ✓ Manifestation films available, offering both style and privacy.

Manifestation & Design Options

The SG35 offers both style and privacy.

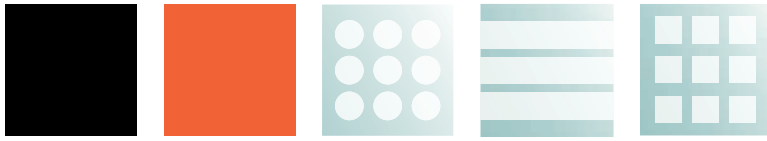

Cross Sections

Track and trolley cross sections.

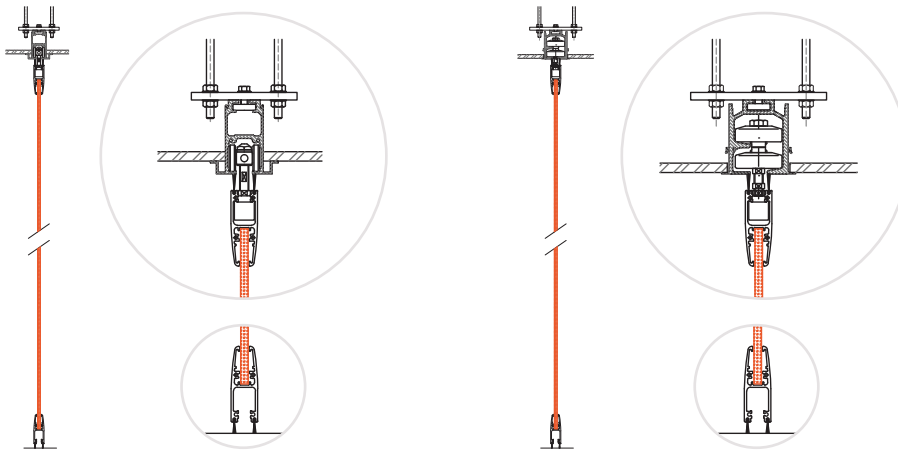

Stacking Arrangement Examples

The SG35 is available in an array of stacking options.

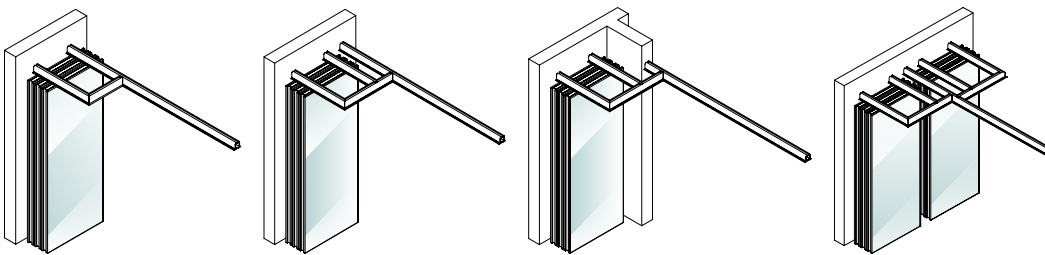

Panel Options

Get the most out of your space with panel and door options.

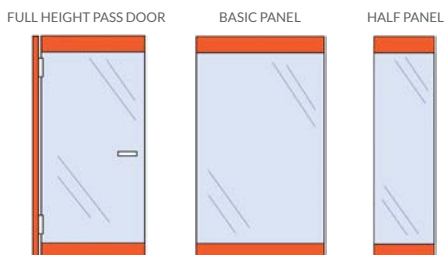



GSF70 Wave | Glazed Sliding Folding System

An aesthetically pleasing system which provides a movable alternative to modern day office fixed partitioning.





GSF70 Wave | Glazed Sliding Folding System

The GSF70 Wave is an aesthetically pleasing system which provides a movable alternative to modern day office fixed partitioning.

The developments of the GSF70 Wave system has acknowledged previous architectural challenges and creates new options for space division for a variety of environments.

Our team has created an aesthetically pleasing system with concealed hinges and a discreet aluminium frame. Available in a wide range of surface finishes and panel configurations. The wave system is quick and easy to operate and includes a great sound reduction level which would match any fixed glazed partition system.

dB Rating	42	43
Panel Thickness	70mm	70mm
Max Height	4m	4m
Max Length	15m	15m
Weight	25-42kg m ²	25-42kg m ²
Panel Width	450mm - 900mm	450mm - 900mm

Extensive Range of Options

The GSF70 can integrate within a wide range of environments.

- ✓ Available in a wide range of surface finishes.
- ✓ A variety of panel options are available.
- ✓ Floor mounted in addition to the top-hung options.

Standard Colour Options

The GSF70 is available in a range of finishes.



Cross Sections

Track and trolley cross sections.

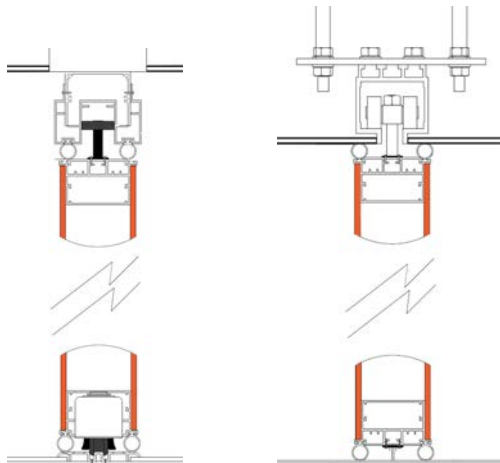

Stacking Arrangement Examples

The GSF70 integrates well into any environment.

SINGLE WING - CENTRE FOLDING

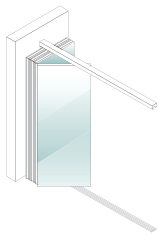

SINGLE WING - END FOLDING

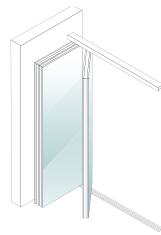

BI-PARTING - CENTRE FOLDING

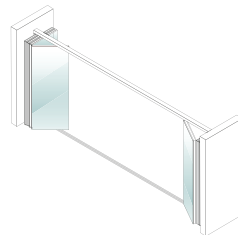

BI-PARTING - END FOLDING

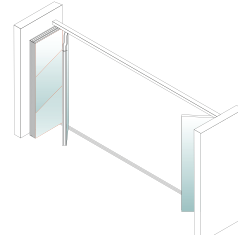

Panel Options

Get the most out of your space with panel and door options.

HALF PANEL



BASIC PANEL

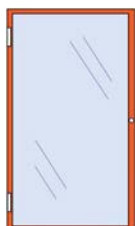

FULL HEIGHT PASS DOOR

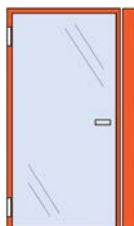

DOUBLE PASS DOOR

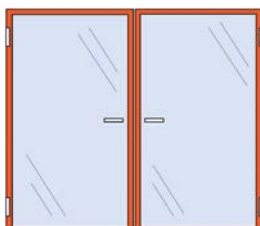

PASS DOOR OPTIONS



Repairs, Servicing and Maintenance

At Acoustic Wall Systems, we can also provide maintenance and service contracts to suit all your needs.

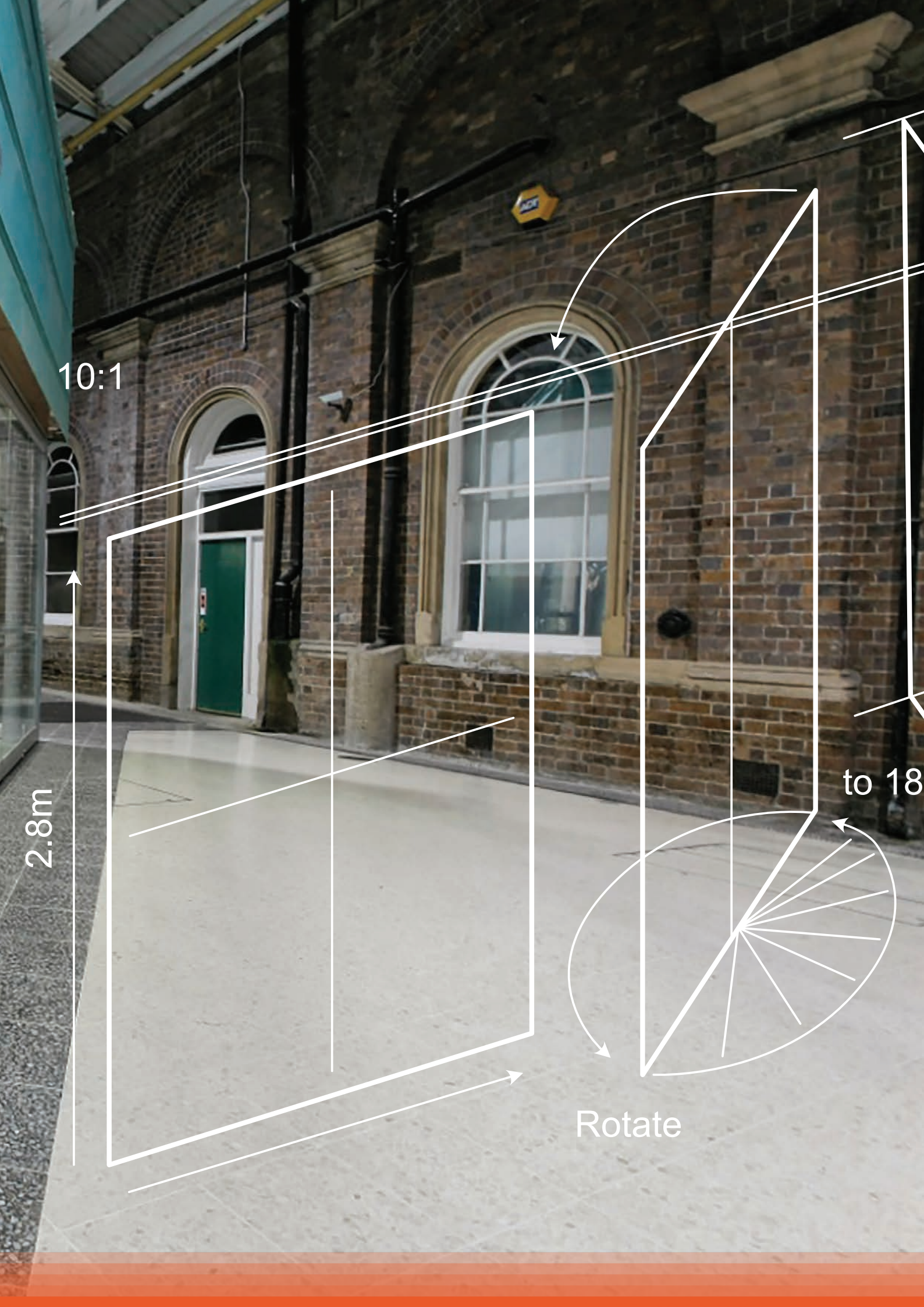

10:1

2.8m

to 18

Rotate

Acoustic Wall Maintenance

At Acoustic Wall Systems we provide maintenance and service contracts to suit all of your requirements.

Acoustic Wall Systems recommends that you perform regularly scheduled maintenance on your operable partition systems.

Regular maintenance helps to keep your acoustic walls in good working order and brings to light any repairs or possible problems you may be unaware of whilst ensuring your operable partitions will provide excellent service year after year.

Regular Servicing and Excellent Aftercare

A regular service helps the track remain free of any dirt and debris which can collect in the tracks over time, maximising the effectiveness and durability of our products.

Panels are easily changed for repair or cosmetic updates including an extensive range of colours and wood effects to suit your every need!

An annual health and safety service/maintenance/health and safety inspection covers the following:

- ✓ Check all track support drop rods and anchor plates are safe.
- ✓ Make sure jamb posts are safe and secure.
- ✓ A thorough check and adjustment of all supporting trolleys and carrier bolts.
- ✓ De-greasing of tracks.
- ✓ Adjust and make level all panels as necessary.
- ✓ Where fitted, to check and secure locking mechanisms and floor sockets.
- ✓ Thoroughly test telescopic closure panel.
- ✓ To test operation and leave working correctly and safe.
- ✓ Full health and safety inspection.
- ✓ 24 hour call out – As per our terms and conditions.
- ✓ Inspection compliance sheet.
- ✓ Provide a full detailed report identifying any further works or parts that may be required.
- ✓ Completion certificate.

For any queries or to arrange a service, repair or aftercare visit call:

01702 813 493







Keep up to date...

